

# **Agilent E2259A Double-Wide Breadboard M-Module**

## **User's Manual and Programming Guide**

### **Where to Find it - Online and Printed Information:**

System installation (hardware/software) ..... VXIbus Configuration Guide\*  
Agilent VIC (VXI installation software)\*

Module configuration and wiring ..... This Manual  
Register-Based Programming ..... This Manual  
Program Examples ..... This Manual

VISA language information ..... Agilent VISA User's Guide

Agilent VEE programming information ..... Agilent VEE User's Manual

*\*Supplied with Agilent Command Modules, Embedded Controllers, and VXLink.*



**Agilent Technologies**



Manual Part Number: E2259-90001  
Printed in Malaysia E0806



Warranty .....	3
Safety Symbols .....	4
WARNINGS .....	4
Declaration of Conformity .....	5
User Notes .....	6

**Chapter 1**

<b>Getting Started .....</b>	<b>9</b>
What's in this Manual? .....	9
Module Description .....	9
General Features .....	9
Block Diagram Description .....	10
Configuring the Module.....	12
Connectors and Access Pads Description .....	13
J100, J101, J104, and J105 Pin Assignment .....	14
J102 and J103 Pin Assignment .....	15
P100, P101, and P102 Pin Assignment .....	16
Assembling the Field Wiring Connector .....	18

**Chapter 2**

<b>Using the Breadboard .....</b>	<b>19</b>
What's in This Chapter .....	19
Registers .....	19
Writing Data to Output Registers .....	20
Using the Write Decoder Lines .....	21
Reading Data From Input Registers.....	22
Using the Read Decoder Lines .....	23
Using the Interrupt .....	24
Program Example .....	25
Resetting the Module .....	28
Hardware Reset .....	28
Software Reset .....	28
Using the Power Supplies .....	28
Application Example .....	29
Relay Selection .....	29

**Chapter 3**

<b>Register Descriptions .....</b>	<b>31</b>
About This Chapter.....	31
Register Addressing in the VXIbus Environment .....	31
Logical Address .....	31
A16/A24 Memory Mapping .....	31
Determining a Module's A16 Base Address .....	32
Addressing A16 Registers .....	33
Addressing A24 Registers .....	33
Program Example .....	35
Register Descriptions .....	37
Registers in A16 Address Space .....	37
Registers in A24 Address Space .....	41

**Appendix A**  
**Agilent E2259A Specifications ..... 45**

---

## Certification

*Agilent Technologies, Inc. certifies that this product met its published specifications at the time of shipment from the factory. Agilent Technologies further certifies that its calibration measurements are traceable to the United States National Institute of Standards and Technology (formerly National Bureau of Standards), to the extent allowed by that organization's calibration facility, and to the calibration facilities of other International Standards Organization members.*

---

## AGILENT TECHNOLOGIES WARRANTY STATEMENT

**PRODUCT:** E2259A

**DURATION OF WARRANTY:** 1 year

1. Agilent warrants Agilent hardware, accessories and supplies against defects in materials and workmanship for the period specified above. If Agilent receives notice of such defects during the warranty period, Agilent will, at its option, either repair or replace products which prove to be defective. Replacement products may be either new or like-new.
2. Agilent warrants that Agilent software will not fail to execute its programming instructions, for the period specified above, due to defects in material and workmanship when properly installed and used. If Agilent receives notice of such defects during the warranty period, Agilent will replace software media which does not execute its programming instructions due to such defects.
3. Agilent does not warrant that the operation of Agilent products will be interrupted or error free. If Agilent is unable, within a reasonable time, to repair or replace any product to a condition as warranted, customer will be entitled to a refund of the purchase price upon prompt return of the product.
4. Agilent products may contain remanufactured parts equivalent to new in performance or may have been subject to incidental use.
5. The warranty period begins on the date of delivery or on the date of installation if installed by Agilent. If customer schedules or delays Agilent installation more than 30 days after delivery, warranty begins on the 31st day from delivery.
6. Warranty does not apply to defects resulting from (a) improper or inadequate maintenance or calibration, (b) software, interfacing, parts or supplies not supplied by Agilent Technologies, (c) unauthorized modification or misuse, (d) operation outside of the published environmental specifications for the product, or (e) improper site preparation or maintenance.
7. TO THE EXTENT ALLOWED BY LOCAL LAW, THE ABOVE WARRANTIES ARE EXCLUSIVE AND NO OTHER WARRANTY OR CONDITION, WHETHER WRITTEN OR ORAL, IS EXPRESSED OR IMPLIED AND AGILENT SPECIFICALLY DISCLAIMS ANY IMPLIED WARRANTY OR CONDITIONS OF MERCHANTABILITY, SATISFACTORY QUALITY, AND FITNESS FOR A PARTICULAR PURPOSE.
8. Agilent will be liable for damage to tangible property per incident up to the greater of \$300,000 or the actual amount paid for the product that is the subject of the claim, and for damages for bodily injury or death, to the extent that all such damages are determined by a court of competent jurisdiction to have been directly caused by a defective Agilent product.
9. TO THE EXTENT ALLOWED BY LOCAL LAW, THE REMEDIES IN THIS WARRANTY STATEMENT ARE CUSTOMER'S SOLE AND EXCLUSIVE REMEDIES. EXCEPT AS INDICATED ABOVE, IN NO EVENT WILL AGILENT OR ITS SUPPLIERS BE LIABLE FOR LOSS OF DATA OR FOR DIRECT, SPECIAL, INCIDENTAL, CONSEQUENTIAL (INCLUDING LOST PROFIT OR DATA), OR OTHER DAMAGE, WHETHER BASED IN CONTRACT, TORT, OR OTHERWISE.

FOR CONSUMER TRANSACTIONS IN AUSTRALIA AND NEW ZEALAND: THE WARRANTY TERMS CONTAINED IN THIS STATEMENT, EXCEPT TO THE EXTENT LAWFULLY PERMITTED, DO NOT EXCLUDE, RESTRICT OR MODIFY AND ARE IN ADDITION TO THE MANDATORY STATUTORY RIGHTS APPLICABLE TO THE SALE OF THIS PRODUCT TO YOU.

---

## U.S. Government Restricted Rights

The Software and Documentation have been developed entirely at private expense. They are delivered and licensed as "commercial computer software" as defined in DFARS 252.227- 7013 (Oct 1988), DFARS 252.211-7015 (May 1991) or DFARS 252.227-7014 (Jun 1995), as a "commercial item" as defined in FAR 2.101(a), or as "Restricted computer software" as defined in FAR 52.227-19 (Jun 1987)(or any equivalent agency regulation or contract clause), whichever is applicable. You have only those rights provided for such Software and Documentation by the applicable FAR or DFARS clause or the Agilent standard software agreement for the product involved.

---

## IEC Measurement Category II Overvoltage Protection

This is a measurement Category II product designed for measurements at voltages up to 300V from earth, including measurements of voltages at typical mains socket outlets. The product should not be used to make voltage measurements on a fixed electrical installation including building wiring, circuit breakers, or service panels.

E2259A Double-Wide Breadboard M-Module User's Manual and Programming Guide



Edition 2 Rev 2

Copyright © 1998-2006 Agilent Technologies, Inc. All Rights Reserved.

---

---

## Documentation History

All Editions and Updates of this manual and their creation date are listed below. The first Edition of the manual is Edition 1. The Edition number increments by 1 whenever the manual is revised. Updates, which are issued between Editions, contain replacement pages to correct or add additional information to the current Edition of the manual. Whenever a new Edition is created, it will contain all of the Update information for the previous Edition. Each new Edition or Update also includes a revised copy of this documentation history page.

Edition 1 .....June 1997  
Edition 2 .....May 1998  
Edition 2 Rev 2 .....August 2006

---

## Trademarks

Microsoft® is a U.S. registered trademark of Microsoft Corporation  
Windows NT® is a U.S. registered trademark of Microsoft Corporation  
Windows® and MS Windows® are U.S. registered trademarks of Microsoft Corporation

---

## Safety Symbols



Instruction manual symbol affixed to product. Indicates that the user must refer to the manual for specific WARNING or CAUTION information to avoid personal injury or damage to the product.



Alternating current (AC)



Direct current (DC).



Indicates hazardous voltages.



Indicates the field wiring terminal that must be connected to earth ground before operating the equipment—protects against electrical shock in case of fault.

**WARNING**

Calls attention to a procedure, practice, or condition that could cause bodily injury or death.

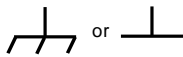

Frame or chassis ground terminal—typically connects to the equipment's metal frame.

**CAUTION**

Calls attention to a procedure, practice, or condition that could possibly cause damage to equipment or permanent loss of data.

---

## WARNINGS

The following general safety precautions must be observed during all phases of operation, service, and repair of this product. Failure to comply with these precautions or with specific warnings elsewhere in this manual violates safety standards of design, manufacture, and intended use of the product. Agilent Technologies, Inc. assumes no liability for the customer's failure to comply with these requirements.

**Ground the equipment:** For Safety Class 1 equipment (equipment having a protective earth terminal), an uninterruptible safety earth ground must be provided from the mains power source to the product input wiring terminals or supplied power cable.

DO NOT operate the product in an explosive atmosphere or in the presence of flammable gases or fumes.

For continued protection against fire, replace the line fuse(s) only with fuse(s) of the same voltage and current rating and type. DO NOT use repaired fuses or short-circuited fuse holders.

**Keep away from live circuits:** Operating personnel must not remove equipment covers or shields. Procedures involving the removal of covers or shields are for use by service-trained personnel only. Under certain conditions, dangerous voltages may exist even with the equipment switched off. To avoid dangerous electrical shock, DO NOT perform procedures involving cover or shield removal unless you are qualified to do so.

**DO NOT operate damaged equipment:** Whenever it is possible that the safety protection features built into this product have been impaired, either through physical damage, excessive moisture, or any other reason, REMOVE POWER and do not use the product until safe operation can be verified by service-trained personnel. If necessary, return the product to an Agilent Technologies Sales and Service Office for service and repair to ensure that safety features are maintained.

**DO NOT service or adjust alone:** Do not attempt internal service or adjustment unless another person, capable of rendering first aid and resuscitation, is present.

**DO NOT substitute parts or modify equipment:** Because of the danger of introducing additional hazards, do not install substitute parts or perform any unauthorized modification to the product. Return the product to an Agilent Technologies Sales and Service Office for service and repair to ensure that safety features are maintained.

---

# DECLARATION OF CONFORMITY

According to ISO/IEC Guide 22 and CEN/CENELEC EN 45014

**Manufacturer's Name:** Agilent Technologies, Incorporated  
**Manufacturer's Address:** *Measurement Product Generation Unit*  
815 14<sup>th</sup> ST. S.W.  
Loveland, CO 80537 USA

**Declares, that the product**

**Product Name:** Breadboard M Module Carrier  
**Model Number:** E2259A  
**Product Options:** *This declaration covers all options of the above product(s).*

**Conforms with the following European Directives:**

*The product herewith complies with the requirements of the Low Voltage Directive 73/23/EEC and the EMC Directive 89/336/EEC and carries the CE Marking accordingly*

**Conforms with the following product standards:**

EMC	Standard	Limit
	<i>IEC 61326-1:1997+A1:1998 / EN 61326-1:1997+A1:1998 CISPR 11:1997 +A1:1997 / EN 55011:1998 IEC 61000-4-2:1995+A1:1998 / EN 61000-4-2:1995 IEC 61000-4-3:1995 / EN 61000-4-3:1995 IEC 61000-4-4:1995 / EN 61000-4-4:1995 IEC 61000-4-5:1995 / EN 61000-4-5:1995 IEC 61000-4-6:1996 / EN 61000-4-6:1996 IEC 61000-4-11:1994 / EN 61000-4-11:1994</i>	<i>Group 1 Class A <sup>[1]</sup> 4kV CD, 8kV AD 3 V/m, 80-1000 MHz 0.5kV signal lines, 1kV power lines 0.5 kV line-line, 1 kV line-ground 3V, 0.15-80 MHz 1 cycle, 100%</i>
	<i>Canada: ICES-001:1998 Australia/New Zealand: AS/NZS 2064.1</i>	
<b>Safety</b>	<i>IEC 61010-1:1990+A1:1992+A2:1995 / EN 61010-1:1993+A2:1995 Canada: CSA C22.2 No. 1010.1:1992 UL 3111-1:1994</i>	
	<i>IEC 950(1991) + A1(1992) + A2(1993) + A3(1994) EN 60950(1992) + A1(1992) + A2(1993) + A3(1994) CSA C22.2#950(1995) UL 1950(1995)</i>	

**Supplemental Information:**

<sup>[1]</sup> *The product was tested in a typical configuration with Agilent Technologies test systems.*

September 5, 2000

Date



Name

Quality Manager

Title

For further information, please contact your local Agilent Technologies sales office, agent or distributor.  
*Authorized EU-representative: Agilent Technologies Deutschland GmbH, Herrenberger Strabe 130, D 71034 Böblingen, Germany*

*Notes:*

---



*Notes:*

---

*Notes:*

---

### What's in this Manual?

This manual contains a module description, configuration and wiring information, and general programming information for the Agilent E2259A Double-Wide Breadboard M-Module. Complete specifications for the breadboard are provided in Appendix A.

The Agilent E2259A is intended to be installed on a carrier such as the Agilent E2251 M-Module Carrier. Refer to the Carrier documentation for M-Module installation information.

This chapter contains general features, a block diagram description, configuration information and connector pinouts for the Agilent E2259A.

### Module Description

The Agilent E2259A is a double-wide breadboard M-Module. As a double-wide module it occupies two adjacent slots in the Carrier. However, it is scored down the middle and can easily be “snapped” in half; with all the active M-Module interface circuits on one of the two halves. See Figure 1-2.

Even though the Agilent E2259A breadboard is a double-wide, in an Agilent E2251 Carrier, the module requires only one VXIbus logical address. When installed in the Carrier the module functions as a standard VXIbus device.

### General Features

The Agilent E2259A provides:

- A8/D16 Register-based M-Module interface circuitry.
- A programmable BUSY Timer (for delaying interrupt acknowledgment of command completion).
- A 16-bit input/output (I/O) Register.
- Read/Write decoder lines
- Support for internal/external interrupts.

## Block Diagram Description

Figure 1-1 shows a simplified block diagram of the Agilent E2259A. In order to effectively program the module you must understand its operation at a block diagram level. The following paragraphs describe the major sections in the block diagram.

### Module Control

This block contains all of the logic for the module including carrier interface, registers, interrupt control, the programmable busy timer, I/O lines, control lines, etc. All lines except the latched data output lines (BC0 - BC15) connect directly to the U101 controller FPGA.

The I/O register at 14H in A24 memory space is realized on this Breadboard. Writing to this register automatically outputs the data on the BC0 - BC15 lines; similarly, reading this register automatically reads the data on the TR0 - TR15 lines. More I/O registers can be expanded by using the decoder lines and additional circuits.

### ID EEPROM

The ID EEPROM holds sixty-four 16-bit words of M-Module ID data and VXI M-Module data.

### Input and Output Circuit

The breadboard data input lines (TR0 - TR15) connect directly from the J103 pads to the U101 controller FPGA. The data output lines (BC0 - BC15) are latched by U107 and U108 (74ACTQ273SM) and are available on J103. Control lines (LAT\*, DBEN\*, CRST\*, etc.) and the I/O Decoder lines (WP0 - WP7 for write decoder lines and RP0 - RP7 for read decoder lines) are available on J102. Refer to Chapter 2 for information on using these lines.

### Power Supplies

The Agilent E2259A Breadboard provides filtered  $\pm 12\text{VDC}$  and  $+5\text{VDC}$  supplies for use on the breadboard. Do not exceed the maximum current specifications for the breadboard (see Appendix A). The active electronics provided on the module use only the  $+5\text{VDC}$  supply.

Each power supply is protected by a positive-temperature-coefficient thermistor. When maximum current through the thermistor is reached, its resistance increases significantly thereby limiting the current; the thermistor acts like a resettable fuse. Table 1-1 lists the power supplies, thermistor protection reference designator (silkscreened on PC board), and the maximum current.

**Table 1-1. Agilent E2259A Power Supply Protection**

	Thermistor Ref. Designator	Maximum Current
+5VDC Supply	F201	1000mA
+12VDC Supply	F200	200mA
-12VDC Supply	F202	200mA

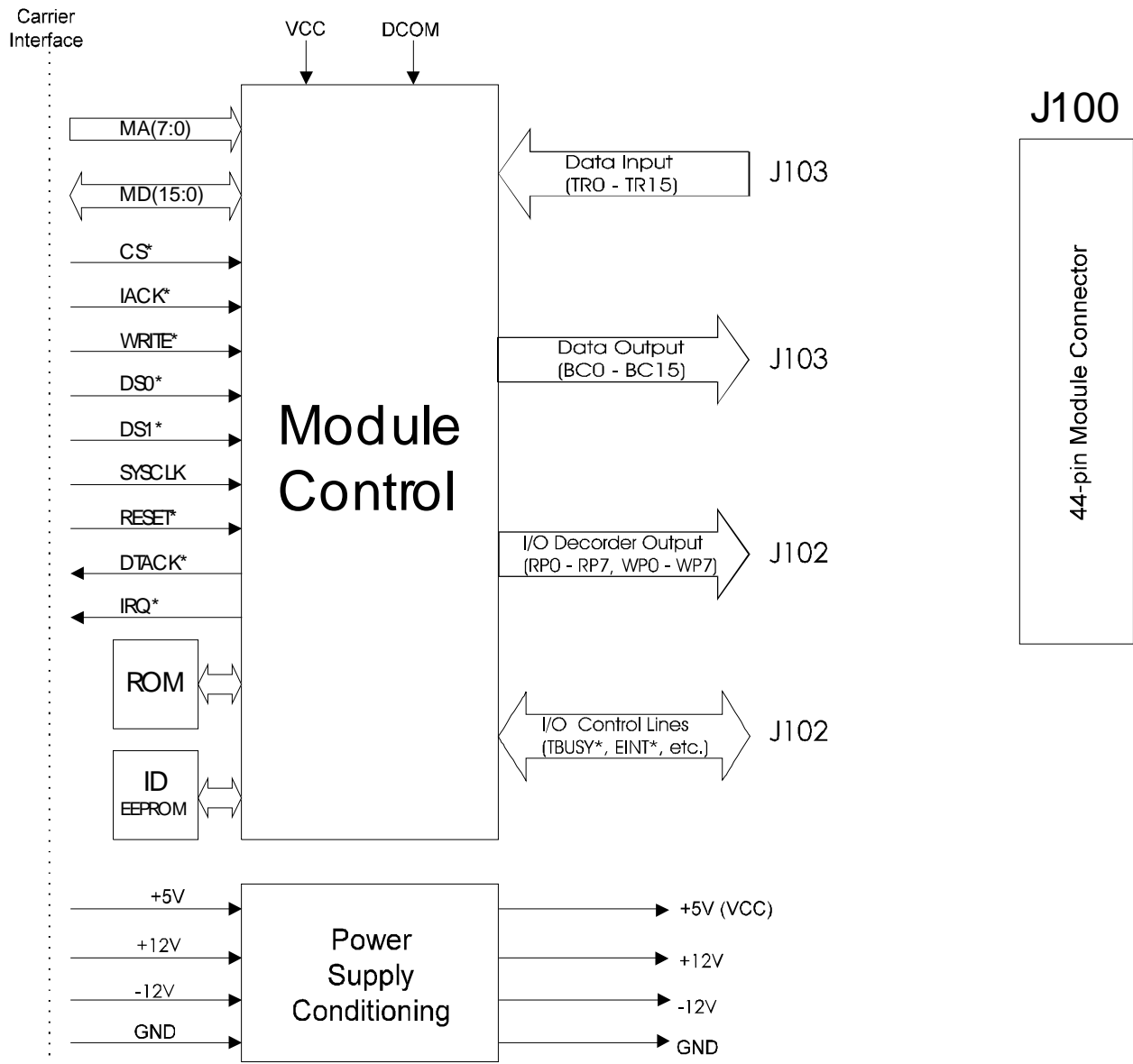

Figure 1-1. Agilent E2259A Block Diagram

# Configuring the Module

This section provides general information to connect user wiring to the breadboard module and provides guidelines for mounting components on the module.

---

**Note** This section does not describe installing the breadboard module in a carrier. Since installation is dependent on the carrier used, you should refer to your carrier's documentation for detailed installation instructions. Each Agilent M-Module is supplied with identifying labels that should be installed on the carrier.

---

---

**WARNING** **SHOCK HAZARD.** Only qualified, service-trained personnel aware of the hazards involved should install, configure, or remove the M-Module. Disconnect all power sources from the mainframe, the terminal module and installed modules before installing or removing a module.

---

---

**Caution** **VOLTAGE/CURRENT.** Pay careful attention to the limitation of maximum voltage/current and maximum power listed in Appendix A. Exceeding any limit or use outside the parameters specified may damage the module and/or carrier.

---

---

**Caution** **STATIC ELECTRICITY.** Static electricity is a major cause of component failure. To prevent damage to the electrical components on an M-Module or the carrier, observe anti-static techniques whenever installing, removing, or working on a carrier or M-Module.

---

# Connectors and Access Pads Description

There are several connectors and access pads on the Agilent E2259A Breadboard. Refer to Figure 1-2. Connector P100 provides the carrier interface to the active electronics on the module. Connector P101 provides access to the carrier interface; all pins on P101 are mapped to access pads on P102 (refer to P100, P101, and P102 Pin Assignment on page 16 for detailed pinout). Access pads J102 and J103 provide access to the buffered input and output lines, read and write decoder lines, busy line, and power supply connections (refer to J102 and J103 Pin Assignment on page 15 for detailed pinout). Connectors J100 and J104 provide connections for user field wiring. J100 directly maps pin-for-pin to access pads on J101; J104 maps pin-for-pin to access pads on J105. Figure 1-2 also shows the maximum component height above the board and maximum lead length below the board.

**Note** Observe the component height restrictions for Regions A and B on the Breadboard. Region A: 0.21 in (5.3mm); Region B: 0.42 in (10.5mm).

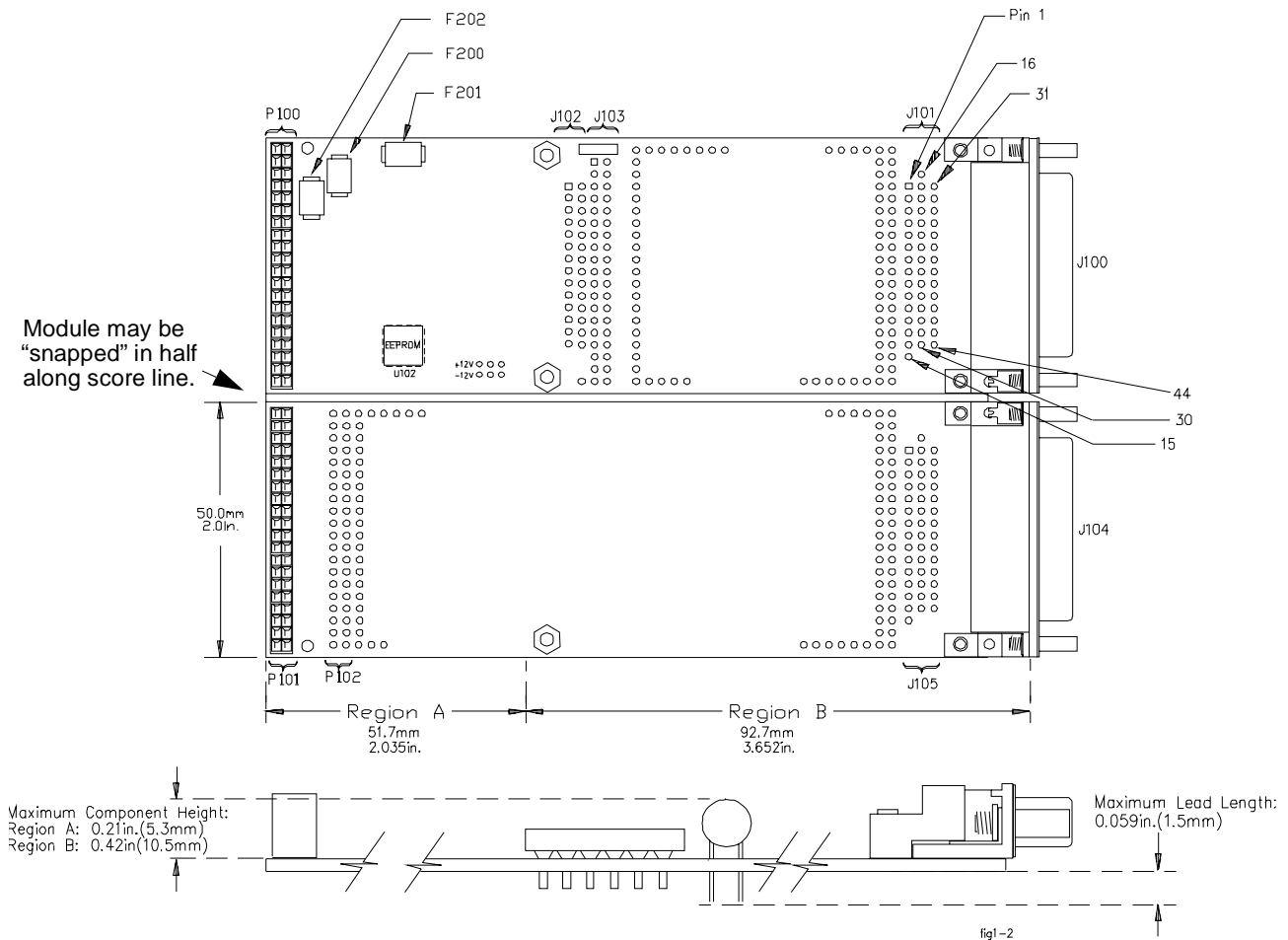
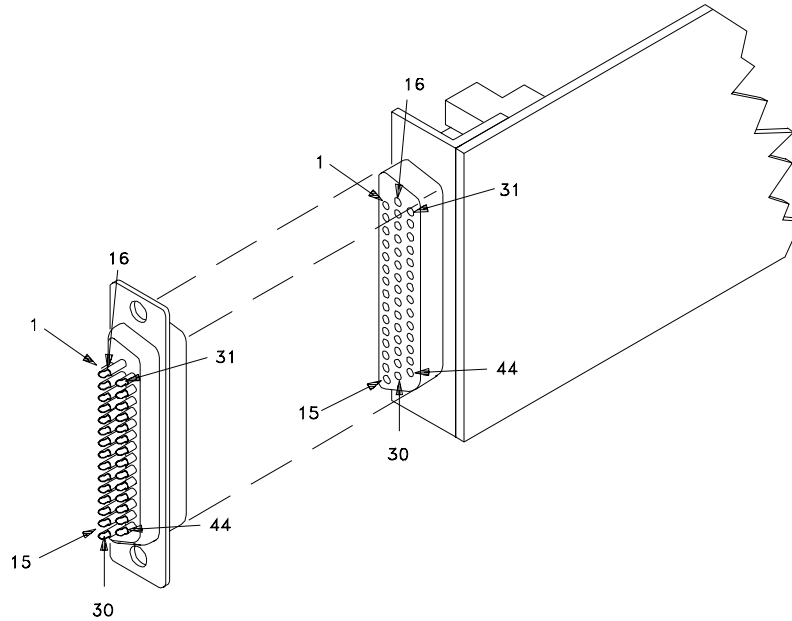

Figure 1-2. Agilent E2259A Connectors Layout

## J100, J101, J104, and J105 Pin Assignment

J100, J101, J104, and J105 are for user field wiring. J100 maps pin-for-pin to J101 (see Figure 1-2) and J104 maps pin-for-pin maps to J105. Figure 1-3 shows the 44-pin field wiring connector pinout. Figure 1-6 shows how to assemble the field wiring connector and hood assembly.

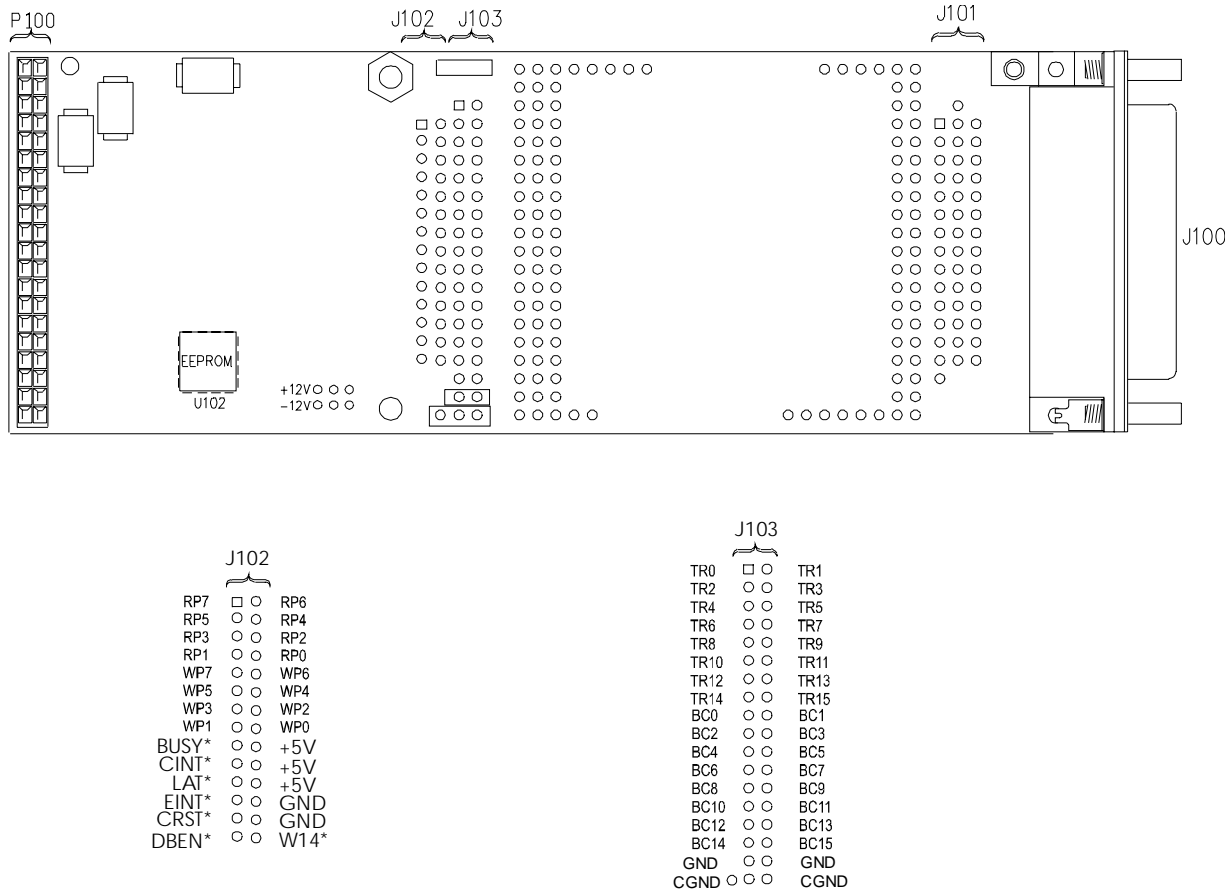

**Figure 1-3. 44-Pin Field Wiring Connector**



## J102 and J103 Pin Assignment

Figure 1-4 shows the pinout for the J102 and J103 pads. Notice that the bottom row of pads on J103 (CGND) are connected to chassis ground through the carrier to the VXibus mainframe. The  $\pm 12\text{VDC}$  pads are located just to the left of the bottom of J102.



**Figure 1-4. J102, J103 Connector Pinouts**

**TR0 - TR15:** Data Input Lines (register address  $14_h$  in A24 Memory).

**BC0 - BC15:** Data Output Lines (register address  $14_h$  in A24 Memory).

**WP0 - WP7:** Write Decoder Lines (address  $20_h$ - $2E_h$  in A24 Memory).

**RP0 - RP7:** Read Decoder Lines (address  $20_h$ - $2E_h$  in A24 Memory).

**BUSY\*:** Delay Timer Output. (Delay Time Reg. Addr.  $12_h$  in A24) output from breadboard.

**CINT\*:** Clear Interrupt. A negative pulse is asserted during interrupt acknowledge if external interrupt request is pending, output from breadboard.

**EINT\*:** User Supplied External Interrupt Request. Falling edge causes interrupt to host controller if enabled.

**LAT\*:** Latch signal for write cycle, output from breadboard.

**CRST\*:** Reset, low means breadboard being reset, output from breadboard.

**DBEN\*:** Data Bus Enable, low to enable data bus, output from breadboard.

**W14\*:** Output Register Latch Signal of  $14H$  in A24 memory space, rising edge latches data into external device, output from breadboard.

**CGND:** Chassis Ground

# P100, P101, and P102 Pin Assignment

Figure 1-5 shows the connector pinouts for P100, P101, and P102. Pin 101 connects to and maps pin-for-pin to P102. The pin names are described on the next page.

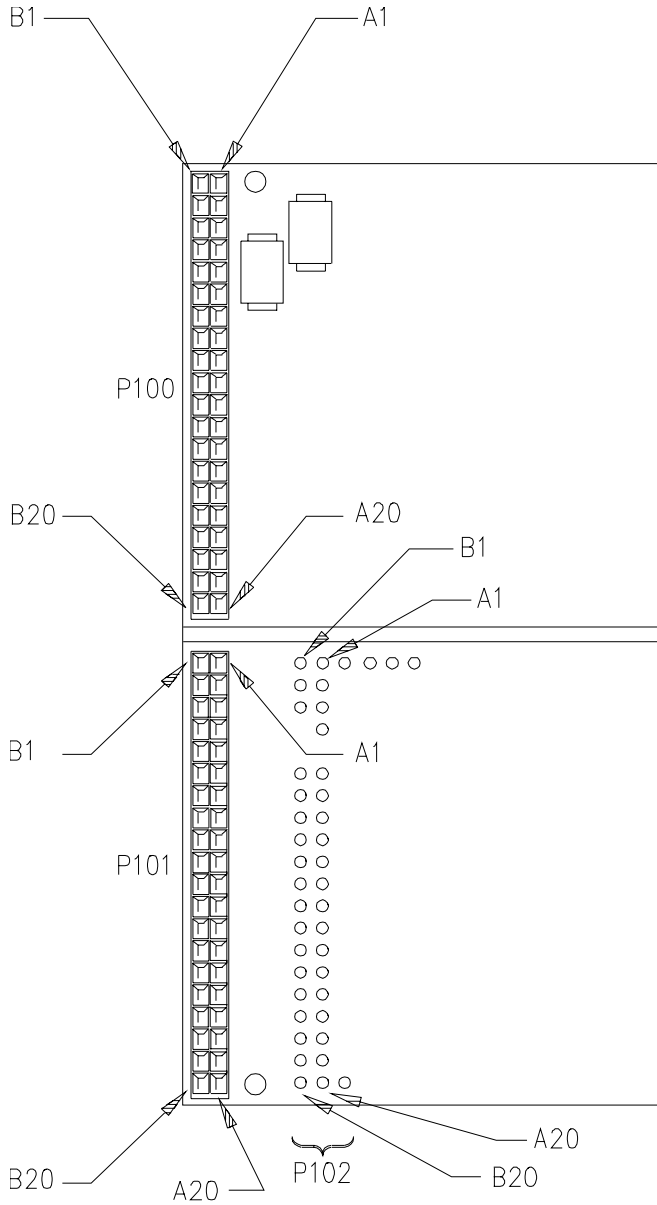

fig1-3

Pin	Col A	Col B
1	CS*	Ground
2	MA01	+5V
3	MA02	+12V
4	MA03	-12V
5	MA04	Ground
6	MA05	DREQ*
7	MA06	DACK*
8	MA07	Ground
9	MD08	MD00
10	MD09	MD01
11	MD10	MD02
12	MD11	MD03
13	MD12	MD04
14	MD13	MD05
15	MD14	MD06
16	MD15	MD07
17	DS1*	DS0*
18	DTACK*	WRITE*
19	IACK*	IRQ*
20	RESET*	SYSCLK

**Figure 1-5. P100, P101, P102 Connectors**

**MA01 to MA07:** M-Module Address Bus, Input to M-Module.

**CS\*:** Card Select Signal, Input to M-Module. Low when the M-Module is being accessed.

**MD00 to MD15:** M-Module Data Bus, Input / Output.

**DACK\*:** Low when carrier is performing a DMA transfer, Input

to M-Module.

<b>DREQ*:</b>	Low to requests a DMA transfer, Output from M-Module.
<b>DS0* - DS1*:</b>	Data Strobe Signal, Input to M-Module 00 = 16 bit data transfer 01 = D15 - D08 transfer 10 = D7 - D0 transfer 11 = no data transfer.
<b>DTACK*:</b>	Data Acknowledge Signal, Output from M-Module. Low to acknowledge data transfer and terminate access.
<b>IACK*:</b>	Interrupt Acknowledge Signal, Input to M-Module. Low when interrupt is being acknowledged.
<b>IRQ*:</b>	Interrupt Request Signal, Output from M-Module. Low to request an interrupt.
<b>RESET*:</b>	System Reset Signal, Input to M-Module. Low to reset the module.
<b>SYSCLK:</b>	16MHz System Clock, Input to M-Module.
<b>WRITE*:</b>	Write Signal, Input to M-Module. Low during writing cycle, high during reading cycle.

# Assembling the Field Wiring Connector

Each Agilent E2259A module includes two 44-pin connector and hood kits (Agilent kit part number E2273-01203). You must supply your own cable. The drawing below shows how to connect wiring and assemble the connector and hood.

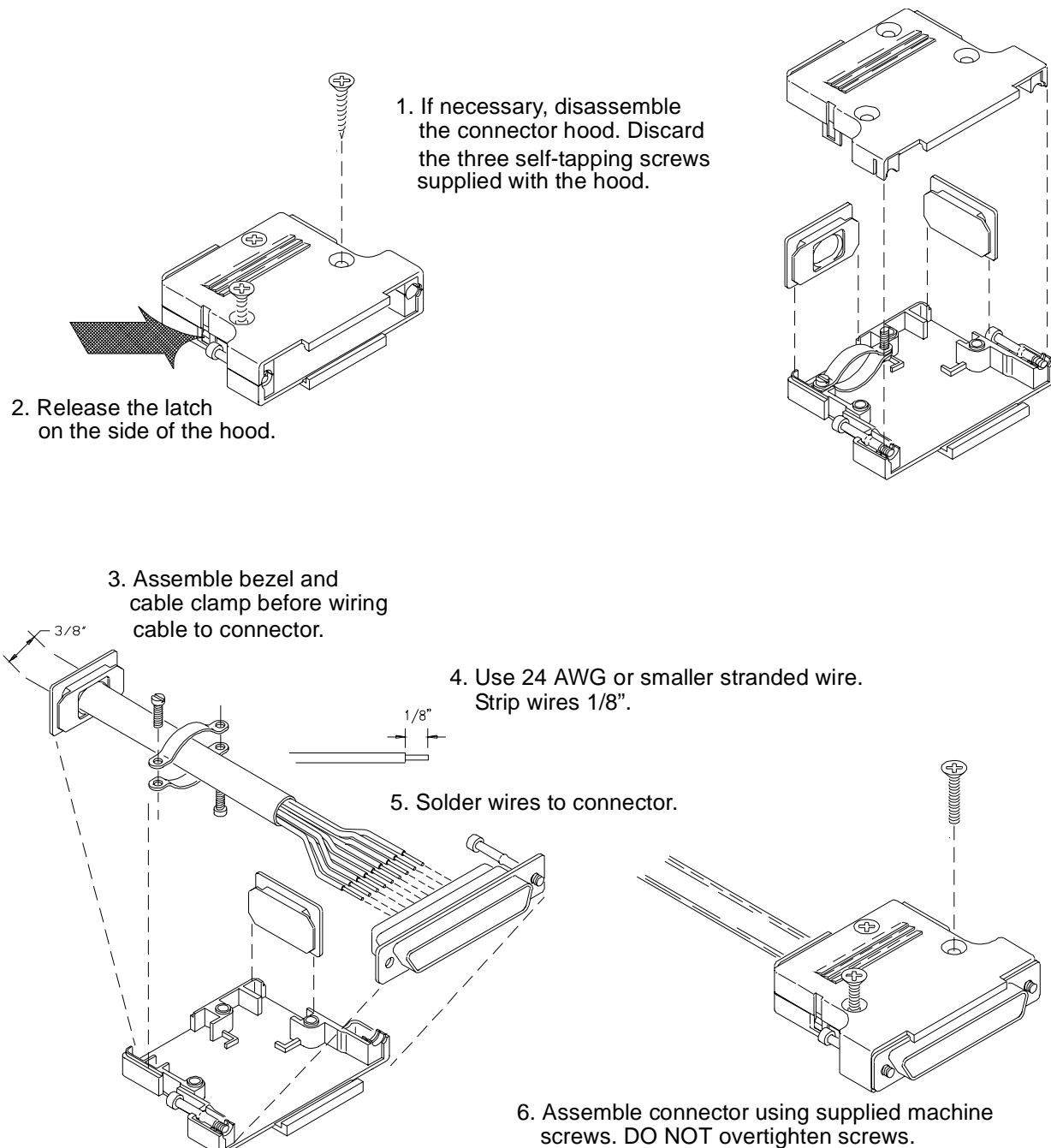

Figure 1-6. Assembling the Field Wiring Connector and Hood

# Chapter 2

## Using the Breadboard

---

### What's in This Chapter

This chapter provides general operating information for the Agilent E2259A Double-wide Breadboard. It also provides a simple application example. The chapter contents include:

- Writing Data to Output Registers . . . . . Page 20
- Reading Data from Input Registers. . . . . Page 22
- Using the Interrupt . . . . . Page 24
- Resetting the Module . . . . . Page 28
- Using the Power Supplies . . . . . Page 28
- Application Example. . . . . Page 29

### Registers

Table 2-1 lists the registers available on the Agilent E2259A Breadboard (Chapter 3 provides a detailed description of all of the registers on the Agilent E2259A.) This section provides information on using the Input/Output Register and the Read/Write Decoder Registers.

**Table 2-1. Agilent E2259A Registers**

Register Name	Register Address	Register Description
VXI ID Register	00 <sub>h</sub> in VXI A16 Memory	Provides Device Class and Manufacturer ID.
VXI Device Type Register	02 <sub>h</sub> in VXI A16 Memory	Provides Model Code for M-Module.
VXI Status/Control Register	04 <sub>h</sub> in VXI A16 Memory	Controls Reset and Provides module Status information.
A24 Offset Register	06 <sub>h</sub> in VXI A16 Memory	Provides A24 Offset Base Address.
Interrupt Selection Register	20 <sub>h</sub> in VXI A16 Memory	Selects VXI Interrupt Line.
Status Register	00 <sub>h</sub> in VXI A24 Memory	Selects Interrupt Source.
Control Register	02 <sub>h</sub> in VXI A24 Memory	Controls Reset and Enables/Disables Interrupt.
Interrupt Register	04 <sub>h</sub> in VXI A24 Memory	Selects Type of Interrupt.
Delay Timer (BUSY) Register	12 <sub>h</sub> in VXI A24 Memory	Sets Delay Value for Command completion interrupt.
Input/Output Register	14 <sub>h</sub> in VXI A24 Memory	Data Input from TR0 - TR15 Lines. Data Output to BC0 - BC15 Lines.
Read/Write Decoder Registers	20 <sub>h</sub> - 2E <sub>h</sub> in VXI A24 Memory	Used to select the latches or buffers supplied by users.

# Writing Data to Output Registers

To output data over the data bus lines (BC0 - BC15), write the data to the I/O register at 14<sub>h</sub> in A24 Memory. Figure 2-1 shows the timing of writing data to the I/O register. You only have access to the DBEN\*, LAT\*, W14\*, and BUSY\* control lines; the other control line waveforms (SYSCLK, DS0\*, DS1\*, CS\*, DTACK\*, and MA0-MA7) are provided for reference information only. Note:

- W14\* has the same timing as LAT\* when writing to 14H in A24 memory space.
- IRQ\* is asserted at the end of the BUSY cycle (see "Using the Interrupt" on page 24). The BUSY\* line pulse lasts 13mS if the module default is used. You can change the BUSY time by writing a value to the Delay Timer Register at address 12<sub>h</sub>. Refer to Chapter 3 for details.
- MD15-MD0 are latched to BC15-BC0 at the rising edge of W14\*.

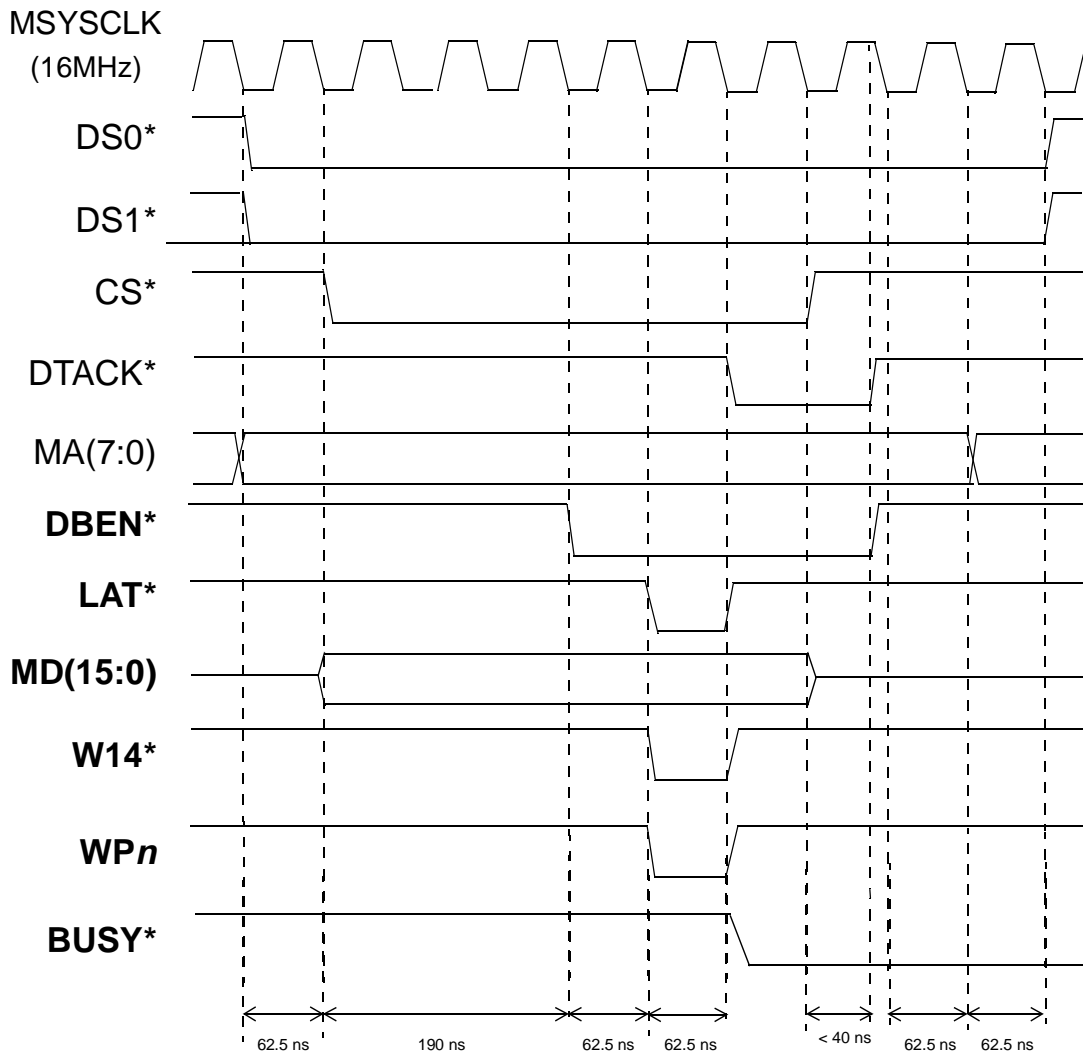

Figure 2-1. Timing of Writing to I/O Register

## Using the Write Decoder Lines

You can use the eight Write Decoder lines (WP0 - WP7) as latch select lines to expand for more output registers. Table 2-2 lists the Read/Write Decoder Register Addresses and the corresponding WP and RP lines.

**Table 2-2. Read/Write Decoder Lines and Register Addresses**

WP / RP Line	Register Address	WP / RP Line	Register Address
WP0 / RP0	20 <sub>h</sub> in A24 Memory	WP4 / RP4	28 <sub>h</sub> in A24 Memory
WP1 / RP1	22 <sub>h</sub> in A24 Memory	WP5 / RP5	2A <sub>h</sub> in A24 Memory
WP2 / RP2	24 <sub>h</sub> in A24 Memory	WP6 / RP6	2C <sub>h</sub> in A24 Memory
WP3 / RP3	26 <sub>h</sub> in A24 Memory	WP7 / RP7	2E <sub>h</sub> in A24 Memory

Figure 2-1 shows the timing required to write output data using one of the Read/Write Decoder Registers and the corresponding WP Line. You only have access to the DBEN\*, LAT\*, WP<sub>n</sub>, and BUSY control lines; the other control line waveforms (SYSCLK, DS0\*, etc.) are provided for reference information only.

- WP<sub>n</sub> has the same timing as LAT\* when writing to the corresponding register address.
- There is no BUSY signal when writing to addresses other than 14H in A24 memory space.
- MD15-MD0 are latched to latches on the rising edge of WP<sub>n</sub>.

Figure 2-2 shows an example of using the WP0 Decoder Line to serve as a device latch signal.

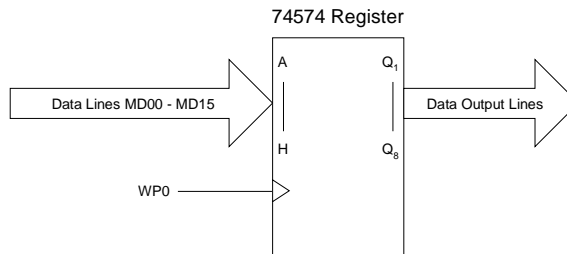

**Figure 2-2. Using the Write Decoder Line WP0**

To create an expanded register, write a data value to the appropriate Read/Write Decoder Register. For example, to use the circuit in Figure 2-2, you would write a 16-bit data value to the WP0 register (address 20<sub>h</sub> in A24 memory).

# Reading Data From Input Registers

To read data from the TR0 - TR15 Data Input lines, read the data from the I/O register at 14<sub>h</sub> in A24 memory space. Figure 2-3 illustrates the timing required for reading data from this register on the Agilent E2259A Breadboard. You only have access to the DBEN\* and LAT\* control lines; the other control line waveforms are provided for reference information only.

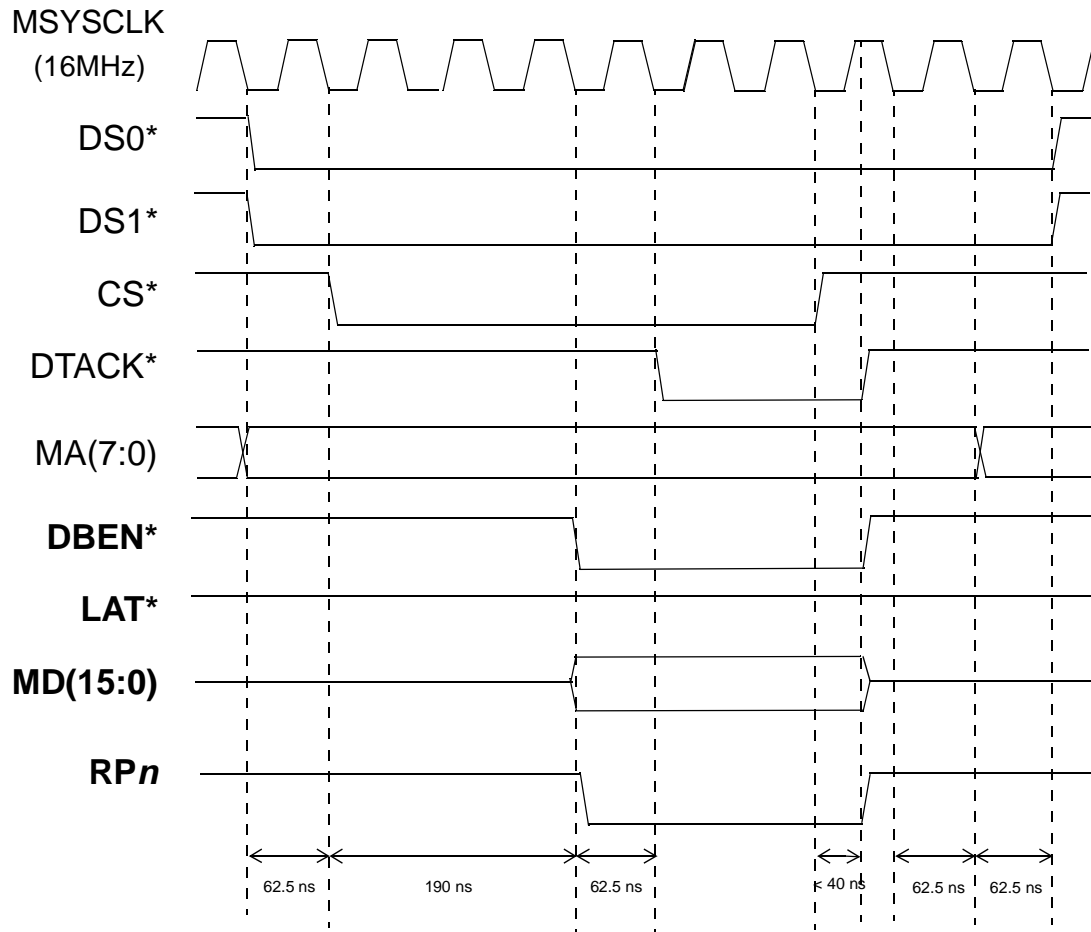

Figure 2-3. Timing of Reading Data from Registers



## Using the Read Decoder Lines

Expanding input registers with read decoder lines RP0-RP7 is similar to expanding output registers (see Figure 2-2 on Page 21), except that a buffer (74245) is used as an input buffer, RP<sub>n</sub> is used as a buffer enable signal, data direction is toward MD15-MD0. The RP<sub>n</sub> lines can be used as select lines to specify which device the data is read from. Figure 2-3 also shows the timing of the RP<sub>n</sub> pulse. Table 2-3 lists the Read/Write Decoder Register Addresses and the corresponding WP and RP lines.

**Table 2-3. Read/Write Decoder Lines and Register Addresses**

WP / RP Line	Register Address	WP / RP Line	Register Address
<b>WP0 / RP0</b>	20 <sub>h</sub> in A24 Memory	<b>WP4 / RP4</b>	28 <sub>h</sub> in A24 Memory
<b>WP1 / RP1</b>	22 <sub>h</sub> in A24 Memory	<b>WP5 / RP5</b>	2A <sub>h</sub> in A24 Memory
<b>WP2 / RP2</b>	24 <sub>h</sub> in A24 Memory	<b>WP6 / RP6</b>	2C <sub>h</sub> in A24 Memory
<b>WP3 / RP3</b>	26 <sub>h</sub> in A24 Memory	<b>WP7 / RP7</b>	2E <sub>h</sub> in A24 Memory

# Using the Interrupt

The Breadboard has a read only Interrupt Register located at address 04<sub>h</sub> in A24 Memory. The contents of this register is used as an interrupt vector to determine which interrupt source caused the interrupt.

If IACK\* (Type C interrupt) is present, the content of the Interrupt Register will be sent to the data bus and the IRQ\* line will be released. Reading the Interrupt Register will clear the interrupt request signal IRQ\* to support Type A interrupt.

Bits 2 through bit 15 of this register are not used. Bit 1 indicates an external interrupt existing if the content of bit 1 is "1". See *Chapter 3, Register Description* for more information of this Interrupt Register.

IRQ\* will be valid whenever the external interrupt occurs.

Figure 2-4 shows the timing for an interrupt acknowledge cycle.

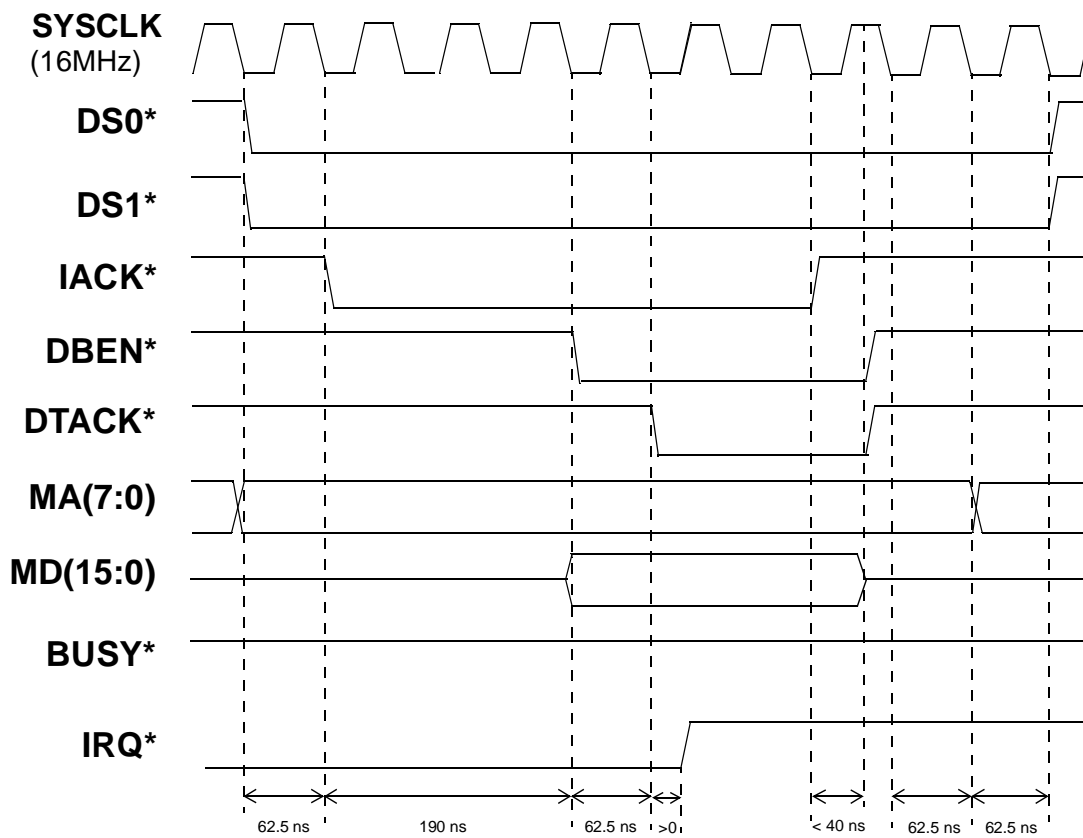

Figure 2-4. Timing for Interrupt Acknowledge Cycle

# Program Example

The following program example demonstrates how to access the registers on the Agilent E2259A. The example uses the VXIplug&play register reads and writes.

The example programs were developed with the ANSI C language using the Agilent VISA extensions. The programs were written and tested in Microsoft<sup>®</sup> Visual C++ but should compile under any standard ANSI C compiler.

To run the programs you must have the Agilent SICL Library, the Agilent VISA extensions, and an Agilent 82340 or 82341 GPIB module installed and properly configured in your PC. An Agilent E1406 Command Module is required for the first program. The Agilent E2259A must be installed in an Agilent E2251A Carrier for access to the A16 VXI registers.

The example programs reset the Agilent E2259A Breadboard M-Module. It then:

- Reads the ID, Device Type, Status, and A24 Memory Offset Registers.
- Writes a value to the I/O Register to output data on BC0 - BC15,
- Writes a value to the WP0 Register to output data on BC0 - BC15,
- Reads a value from the I/O Register to input data on TR0 - TR15,
- Reads a value from the RP0 Register to input data on TR0 - TR15.

```
#include <visa.h>
#include <stdio.h>
#include <stdlib.h>

ViSession viRM,m_mod;
int main()
{
    unsigned short id_reg,dt_reg ;           /* ID & Device Type Registers */
    unsigned short stat_reg, a24_offset ;    /* Status & A24 Offset Reg */
    short value;                             /* register variable */

    ViStatus errStatus;                      /*Status from each VISA call*/

    /* Open the default resource manager */
    errStatus = viOpenDefaultRM ( &viRM);
    if (VI_SUCCESS > errStatus){
        printf("ERROR: viOpenDefaultRM() returned 0x%x\n",errStatus);
        return errStatus;}

    /* Open the M-Module instrument session */
    errStatus = viOpen(viRM,"GPIB-VXI0::8",VI_NULL,VI_NULL,&m_mod);
    if (VI_SUCCESS > errStatus){
        printf("ERROR: viOpen() returned 0x%x\n",errStatus);
        return errStatus;}
```

```

        /* read and print the module's ID Register */
errStatus = viln16(m_mod,VI_A16_SPACE,0x00,&id_reg);
if (VI_SUCCESS > errStatus){
    printf("ERROR: viln16() returned 0x%x\n",errStatus);
    return errStatus;}
printf("ID register = 0x%4X\n", id_reg);

        /* read and print the module's Device Type Register */
errStatus = viln16(m_mod,VI_A16_SPACE,0x02,&dt_reg);
if (VI_SUCCESS > errStatus){
    printf("ERROR: viln16() returned 0x%x\n",errStatus);
    return errStatus;}
printf("Device Type register = 0x%4X\n", dt_reg);

        /* read and print the module's Status Register */
errStatus = viln16(m_mod,VI_A16_SPACE,0x04,&stat_reg);
if (VI_SUCCESS > errStatus){
    printf("ERROR: viln16() returned 0x%x\n",errStatus);
    return errStatus;}
printf("Status register = 0x%hx\n", stat_reg);

        /* read and print the module's A24 Offset Register */
errStatus = viln16(m_mod,VI_A16_SPACE,0x06,&a24_offset);
if (VI_SUCCESS > errStatus){
    printf("ERROR: viln16() returned 0x%x\n",errStatus);
    return errStatus;}
printf("A24 Offset register value = 0x%hx\n", a24_offset);

        /* Write a value of AA to I/O Register, Addr 0x14 */
errStatus = viOut16(m_mod,VI_A24_SPACE,0x14,0xAA);
if (VI_SUCCESS > errStatus){
    printf("ERROR: viOut16() returned 0x%x\n",errStatus);
    return errStatus;}

        /* Write a value of FF to WPO Register, Addr 0x20 */
errStatus = viOut16(m_mod,VI_A24_SPACE,0x20,0xFF);
if (VI_SUCCESS > errStatus){
    printf("ERROR: viOut16() returned 0x%x\n",errStatus);
    return errStatus;}

        /* Read the value from I/O Register, Addr 0x14 */
errStatus = viln16(m_mod,VI_A24_SPACE,0x14,&value);
if (VI_SUCCESS > errStatus){
    printf("ERROR: viOut16() returned 0x%x\n",errStatus);
    return errStatus;}
printf("0x14 register value = 0x%hx\n", value);

```

```

        /* Read the value from WP0 Register, Addr 0x20 */
errStatus = viIn16(m_mod,VI_A24_SPACE,0x20,&value);
if (VI_SUCCESS > errStatus){
    printf("ERROR: viOut16() returned 0x%x\n",errStatus);
    return errStatus;}
printf("0x20 register value = 0x%hx\n", value);

        /* Close the M-Module Instrument Session */
errStatus = viClose (m_mod);
if (VI_SUCCESS > errStatus) {
    printf("ERROR: viClose() returned 0x%x\n",errStatus);
    return 0;}

        /* Close the Resource Manager Session */
errStatus = viClose (viRM);
if (VI_SUCCESS > errStatus) {
    printf("ERROR: viClose() returned 0x%x\n",errStatus);
    return 0;}

return VI_SUCCESS;

}

```

# Resetting the Module

There are two ways to reset the module and your own external circuitry. The CRST\* signal line is available on J102 which is available to reset your circuitry (active low).

**Hardware Reset** Whenever you apply power to the system, the Agilent E2259A breadboard module will also be reset. This pulses the CRST\* line low.

**Software Reset** You can also write a “1” to bit 0 of the Control Register (address 04<sub>h</sub> in A16 memory, refer to Chapter 3 for details). This will reset the M-Module and pulse the CRST\* line. You must write a “0” to bit 0 of the Control Register after the reset is finished.

# Using the Power Supplies

Each power supply available for use by external circuits is protected by a positive-temperature-coefficient thermistor. When maximum current through the thermistor is reached, it heats up, and its resistance increases significantly thereby limiting the current; the thermistor acts like a resettable fuse. Table 2-4 lists the power supplies, thermistor protection reference designator (silkscreened on PC board), and the maximum current.

**Table 2-4. Agilent E2259A Power Supply Protection**

	<b>Thermistor Ref. Designator</b>	<b>Maximum Current</b>	<b>Connector</b>	<b>Application</b>
+5VDC Supply	F201	1000mA	J102	Main power source for all systems. Used for supplying power to logic device.
+12VDC Supply	F200	200mA	Near J102	General purpose power for switching power convertors, analog devices and disc drives.
-12VDC Supply	F202	200mA	Near J102	General purpose power for analog devices and disc drives. Not recommended for power convertors.

# Application Example

This section contains a simplified example application using the breadboard module as an 8-channel Form-C Relay module. See Figure 2-6. You must supply the relay driver IC, flyback protection, etc. These have been omitted from the drawing for simplification.

## Relay Selection

The I/O Register is used as the interface. To open one specific relay, you need to WRITE a “0” to the bit of the I/O Register which corresponds to that relay. To close a channel, you need to write a “1” to the corresponding I/O Register bit.

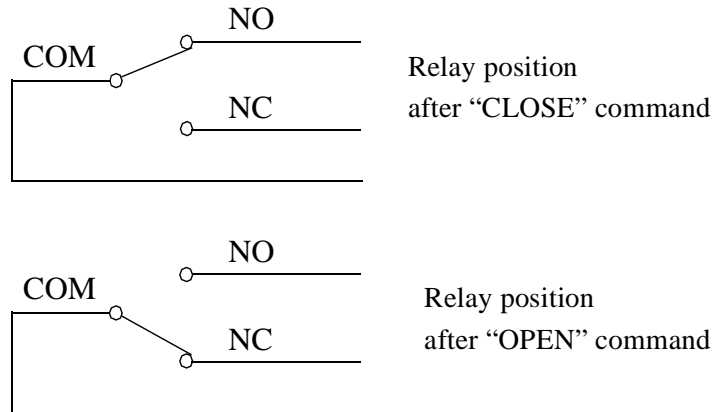

**Figure 2-5. Write a “1” or “0” to the Register Bit to Close/Open the Relay**

The status of all relays must be specified simultaneously. To change just one relay, it is necessary to change the corresponding bit and send the entire pattern again.

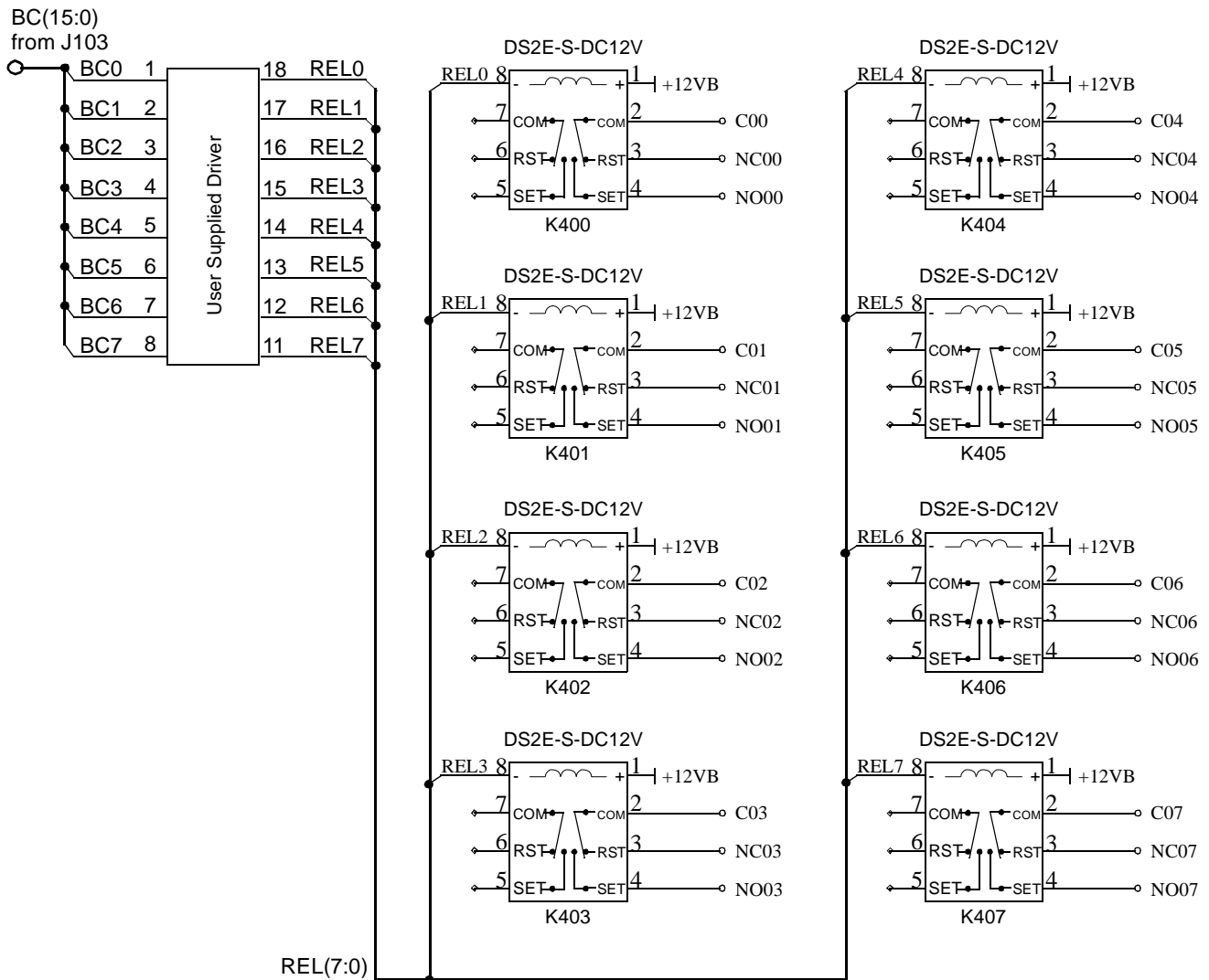

The 16-bit I/O Register of Agilent E2259A is used to control and readback 8 Form-C Relays.

Figure 2-6. Using the Breadboard as an 8-Channel Form C Relay Module



### About This Chapter

This chapter contains register addressing information; it also provides the register description of Agilent E2259A Double-Wide Breadboard M-Module. Chapter contents include:

- Register Addressing in the VXI Environment . . . . . Page 31
- Register Descriptions . . . . . Page 37

---

**Note** Most of the descriptions in this chapter assume the Agilent E2259A is installed in an Agilent E2251A Carrier. The Carrier provides access to the VXI registers.

---

### Register Addressing in the VXIbus Environment

**Logical Address** Each module in a VXIbus (VXI) system, whether VXI or M-Module, must have a unique logical address. The Agilent E2251 Carrier provides a logical address for each installed M-Module. Refer to the Agilent E2251 Installation and Getting Started Guide for details (if you are using a different carrier, refer to that carrier's documentation for register-based addressing information).

**A16/A24 Memory Mapping** The VXI Specification allows for only 64 bytes of address space in A16 memory. However, the M-Module Specification defines 256 bytes of address space. To resolve this conflict, the Agilent E2251 Carrier provides two memory segments for each installed M-Module. The first is in the VXI A16 memory space and contains the standard VXI registers. The second memory segment is in the VXI A24 memory space and contains all other M-Module registers (these registers are described starting on Page 41). Figure 3-1 shows the A16/A24 mapping for a typical M-Module.

---

**Note** The M-Module's ID word (from the ID EEPROM) is mapped into the VXI Manufacturer ID Register at address 00<sub>h</sub> and the M-Module's VXI Device Type word is mapped into the VXI Device Type Register at address 02<sub>h</sub>.

---

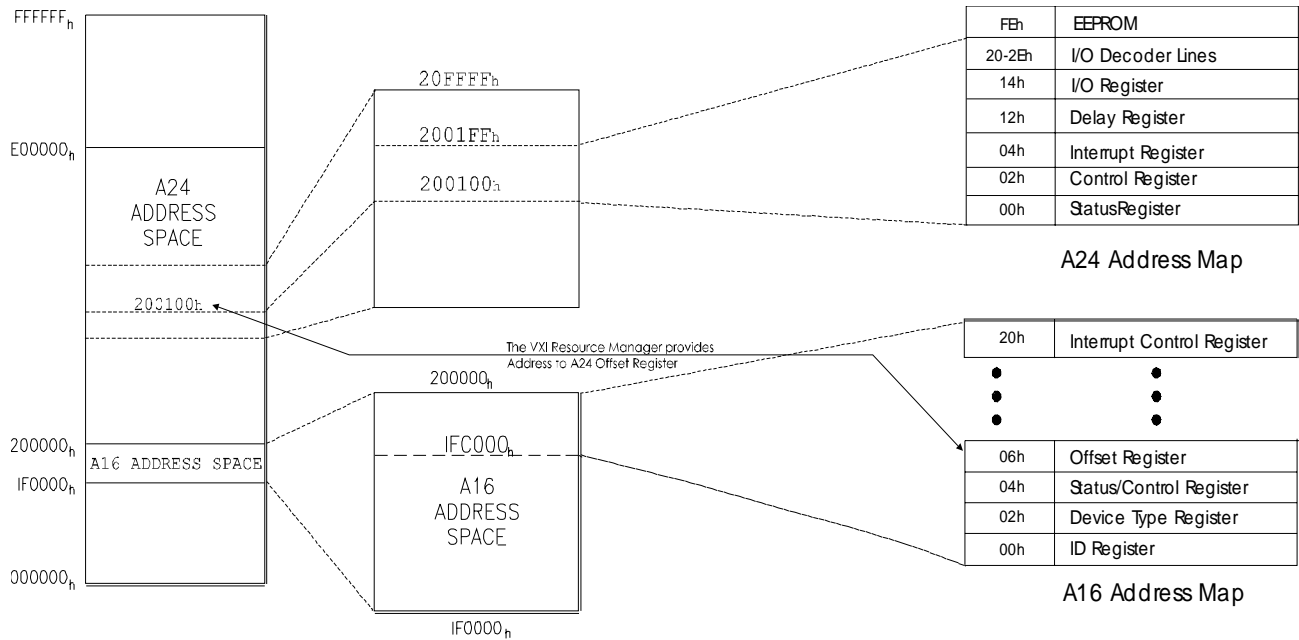

$$* \text{ Base Address} = 1FC000_{16} + (\text{Logical Address} * 64)_{16} \text{ or}$$

$$= 2,080,768_{10} + (\text{Logical Address} * 64)_{10}$$

$$\text{A16 Register Address} = \text{Base Address} + \text{Register Offset}$$

For M-Modules, the Register Address is Computed as:

$$\text{Base Address} = \text{Value in Offset Register}$$

$$\text{Register Address} = \text{Base Address} + \text{Register Offset}$$

(A24 address space)

For Example, in above case, the I/O Register Address is:

$$\text{I/O Register Address} = 200100_{16} + 14_{16} = 200114_{16} \text{ or}$$

$$= 2,097,408_{10} + 20_{10} = 2,907,428_{10}$$

**Figure 3-1. A16/A24 Memory Mapping**

## Determining a Module's A16 Base Address

To access a register in A16 memory, you must specify a hexadecimal or decimal register address. This address consists of a base address plus a register offset. The A16 base address depends on whether or not you are using an Agilent E1406 Command Module.

### A16 Address Space Inside the Command Module

When using an Agilent E1406 Command Module, the base address is computed as:

$$1FC000_h + (\text{LADDR}_h \cdot 40_h)$$

or (decimal)

$$2,080,768 + (\text{LADDR} \cdot 64)$$

Where:

1FC000<sub>h</sub> (2,080,768) is the A16 starting address

LADDR is the module's logical address

$40_h$  (64) is the number of address bytes allocated per module

For example, if the M-Module has a logical address of  $78_h$  (120) the A16 base address becomes:

$$1FC000_h + (78_h \cdot 40_h) = 1FC000_h + 1E00_h = 1FDE00_h$$

*or* (decimal)

$$2,080,768 + (120 \cdot 64) = 2,080,768 + 7680 = 2,088,448$$

### A16 Address Space Outside the Command Module

**When an Agilent E1406 Command Module is not part of your system,** the base address is computed as:

$$C000_h + (LADDR_h \cdot 40_h)$$

*or* (decimal)

$$49,152 + (LADDR \cdot 64)$$

Where:

$C000_h$  (49,152) is the A16 starting address

LADDR is the module's logical address

$40_h$  (64) is the number of address bytes allocated per module

For example, if the M-Module has a logical address of  $78_h$  (120) the A16 base address becomes:

$$C000_h + (78_h \cdot 40_h) = C000_h + 1E00_h = DE00_h$$

*or* (decimal)

$$49,152 + (120 \cdot 64) = 49,152 + 7680 = 56,832$$

### Addressing A16 Registers

As shown in Figure 3-1, VXI registers for an M-Module are mapped into A16 address space by the Agilent E2251 Carrier. To access one of these registers, add the A16 base address to the register offset. For example, an M-Module's VXI Status/Control Register has an offset of  $04_h$ . To access this register (assuming the system does not have an Agilent E1406 Command Module), use the register address:

$$1FDE00_h + 04_h = 1FDE04_h$$

*or* (decimal)

$$2,088,488 + 4 = 2,088,492$$

### Addressing A24 Registers

As shown in Figure 3-1, most of the registers for an M-Module are mapped into A24 address space. To access one of these registers:

1. Obtain the A24 base address by reading the VXI Offset Register ( $06_h$ ) in A16 memory.
2. Add the A24 base address to the register offset (see Table 3-2).

For example, if the A24 base address is  $200100_h$ , to access the Output Register ( $10_h$ ):

$$200100_h + 10_h = 200110_h$$

*or* (decimal)  
 $2,097,408 + 16 = 2,097,424$

# Program Example

The following sample program demonstrates how to write to and read from registers on the Agilent E2259A. The program was developed with the ANSI C language using the Agilent VISA extensions. The program was written and tested in Microsoft Visual C++ but should compile under any standard ANSI C compiler.

To run the program you must have the Agilent SICL Library, the Agilent VISA extensions, and an Agilent 82340 or 82341 GPIB module installed and properly configured in your PC. An Agilent E1406 Command Module provides direct access to the VXI backplane. The Agilent E2259A must be installed in an Agilent E2251A Carrier for access to the A16 VXI Registers.

```
#include <visa.h>
#include <stdio.h>
#include <stdlib.h>

ViSession viRM,m_mod

int main()
{
    ViStatus errStatus;                               /*Status from each VISA call*/
                                                       session*/

    /* Open the default resource manager */
    errStatus = viOpenDefaultRM (&viRM);
    if(VI_SUCCESS > errStatus){
        printf("ERROR: viOpenDefaultRM() returned 0x%x\n",errStatus);
        return errStatus;}

    /* Open the M-Module instrument session */
    errStatus = viOpen(viRM,INSTR_ADDR, VI_NULL,VI_NULL,&m_mod);
    if(VI_SUCCESS > errStatus){
        printf("ERROR: viOpen() returned 0x%x\n",errStatus);
        return errStatus;}

    /* read and print the module's ID Register */
    errStatus = viln16(m_mod,VI_A16_SPACE,0x00,&id_reg);
    if (VI_SUCCESS > errStatus){
        printf("ERROR: viln16() returned 0x%x\n",errStatus);
        return errStatus;}
    printf("ID register = 0x%hx\n", id_reg);

    /* read and print the module's Device Type Register */
    errStatus = viln16(m_mod,VI_A16_SPACE,0x02,&dt_reg);
    if (VI_SUCCESS > errStatus){
        printf("ERROR: viln16() returned 0x%x\n",errStatus);
        return errStatus;}
    printf("Device Type register = 0x%hx\n", dt_reg);

    /* read and print the module's Status Register */
    errStatus = viln16(m_mod,VI_A16_SPACE,0x04,&stat_reg);
    if (VI_SUCCESS > errStatus){
        printf("ERROR: viln16() returned 0x%x\n",errStatus);
        return errStatus;}
}
```

```

printf("Status register = 0x%hx\n", stat_reg);

/* read and print the module's A24 Offset Register */
errStatus = viIn16(m_mod,VI_A16_SPACE,0x06,&a24_offset);
if(VI_SUCCESS > errStatus){
printf("ERROR: viOpen() returned 0x%x\n",errStatus);
return errStatus;}
printf("A24 Offset register value = 0x%hx\n", a24_offset);

/* set the BUSY Delay Timer to 15mS (see Busy Timer) */
errStatus = viOut16 (m_mod,VI_A24_SPACE,0x12,0x1D6);
if (VI_SUCCESS > errStatus){
printf("ERROR: viOut16() returned 0x%x\n",errStatus);
return errStatus;}

/* Output a Value of 5 on BCn Data Lines */
errStatus = viOut16 (m_mod,VI_A24_SPACE,0x14,0x05);
if (VI_SUCCESS > errStatus){
printf("ERROR: viOut16() returned 0x%x\n",errStatus);
return errStatus;}

/* Close the M-Module Instrument Session */
err_status = viClose (m_mod);
if (VI_SUCCESS > errStatus) {
printf("ERROR: viClose() returned 0x%x\n",errStatus);
return 0;}

/* Close the Resource Manager Session */
err_status = viClose (viRM);
if (VI_SUCCESS > errStatus) {
printf("ERROR: viClose() returned 0x%x\n",errStatus);
return 0;}

return VI_SUCCESS;
}

```

# Register Descriptions

There are two sets of registers in the memory window of M-Modules. One is the same as a standard VXIbus instrument register in A16 address space (provided by the Agilent E2251A Carrier), the other is in A24 address space.

## Registers in A16 Address Space

The five registers including the VXI ID Register, VXI Device Type Register, Status/Control Register, Offset Register, Interrupt Control These register are mapped in A16 address space.

Table 3-1 lists the five registers in the A16 memory space. The following paragraphs describe each register.

**Table 3-1. VXIbus A16 Memory Instrument Registers**

Address Mapping	Registers
00 <sub>h</sub>	VXI ID Register
02 <sub>h</sub>	VXI Device Type Register
04 <sub>h</sub>	VXI Status/Control Register
06 <sub>h</sub>	VXI Offset Register
20 <sub>h</sub>	M-Module Interrupt Control Register

### VXI ID Register

The ID Register is a read only register at address 00<sub>h</sub> and provides instrument identification information.

b+00 <sub>h</sub>	15	14	13	12	11	10	9	8	7	6	5	4	3	2	1	0
Write	Undefined															
Read	Device Class		Address Space		Manufacturer ID											

- **Device Class:** this bit should always be 11 indicating a register-based device.
- **Address Space:** 00 indicating A16/A24 device
- **Manufacturer ID:** 4095 (decimal) for Agilent Technologies M-Modules

### VXI Device Type Register

The Device Type Register is a read only register at address 02<sub>h</sub>. Reading this register returns a unique identifier for each M-Module.

b+02 <sub>h</sub>	15	14	13	12	11	10	9	8	7	6	5	4	3	2	1	0
Write	Undefined															
Read	Required Memory				M-Module Model Code											

- **Required Memory:** F<sub>h</sub> indicating 256 byte block required.
- **M-Module Model Code:** 258<sub>h</sub> for the Agilent E2259A.

## VXI Status/Control Register

The Status/Control Register is a read/write register (address 04<sub>h</sub>) that controls the module and indicates its status.

b+04 <sub>h</sub>	15	14	13	12	11	10	9	8	7	6	5	4	3	2	1	0
Write (Control)	A24 Enable	Reserved												Sysfail Inhibit	Reset	
Read (Status)	A24 Active	MODID*	M-Module Device Dependent								Ready	Passed	Device Dependent			

- **A24 Enable.** A 1 in this bit means access to the devices A24 registers is enabled.
- **Sysfail Inhibit.** Writing a 1 disables the M-Module from driving the SYSFAIL\* line.
- **Reset.** Writing a 1 then a 0 to this bit forces the M-Module to reset.
- **A24 Active.** A 1 in this bit indicates the M-Module's registers in A24 memory space can be accessed. Default = 1.
- **MODID\*.** A 1 in this bit indicates that the M-Module is not selected via the P2 MODID line. A 0 indicates the M-Module is selected by a high state on the P2 MODID line.
- **Ready.** A 1 in this bit indicates that the M-Module is ready to accept commands. A 0 indicates the M-Module is busy and not ready to accept commands.
- **Passed.** A 1 in this bit indicates the M-Module passed its self test successfully. A 0 indicates the M-Module is either executing or has failed its self test.

## VXI Offset Register

The Offset Register (address 06<sub>h</sub>) contains the value of the base address for accessing registers in the A24 address space.

b+06 <sub>h</sub>	15	14	13	12	11	10	9	8	7	6	5	4	3	2	1	0
Write	Register written to by VXI Resource Manager. Do not attempt to write to this register.															
Read	A24 Space Base address for those M-Modules needing A24 memory															



## Interrupt Selection Register

The Interrupt Selection Register (address  $20_h$ ) specifies which VXI interrupt line the M-Module will use. M-Modules may generate interrupts to indicate that a SCPI command has completed. These interrupts are sent to and acknowledged by the Agilent Command Module or other system controller via one of seven VXI backplane interrupt lines. Different controllers treat the interrupt lines differently, and you should refer to your controller's documentation to determine how to set the interrupt level. Agilent Command Modules configured as VXI Resource Managers treat all interrupt lines as having equal priority. For interrupters using the same line, priority is determined by which slot they are installed in; lower-numbered slots have higher priority than higher-numbered slots. Agilent Command Modules service line 1 by default, so it is normally correct to leave the interrupt level set to the factory default of IRQ1.

$b+20_h$	15	14	13	12	11	10	9	8	7	6	5	4	3	2	1	0
Write	Reserved												INT	VXI Interrupt Line		
Read	Reserved												INT 1	0	0	1

If your controller's documentation instructs you to change the interrupt level, you need to specify the level in the VXI Interrupt Selection Register. To cause the M-Module to interrupt on one of the VXI interrupt lines, write to the appropriate bits (refer to table below). To disable the module's interrupt, set the bits to 000. Selecting other than the default interrupt line 1 is not recommended. Reading the default value of this register returns the value  $XXX9_h$ .

Bits 2 - 0	Selected Interrupt Line
000	NONE (Interrupt Disabled)
001	IRQ1 (default)
010	IRQ2
011	IRQ3
100	IRQ4
101	IRQ5
110	IRQ6
111	IRQ7

M-Module specifications define three types of interrupts. The INT bit (bit 3) determines which M-Module interrupt style is supported. If INT is set to a 0, the M-Module supports interrupt types A and B. If INT is set to a 1, the M-Module supports interrupt type C (this is the default).

**Type A Interrupts** The interrupting M-Module removes the interrupt request upon a register access (software method) to the interrupting M-Module (such as reading the Status Register). DTACK\* is not asserted during interrupt acknowledge.

**Type B Interrupts** The interrupting M-Module removes the interrupt request via a hardware method (on IACK\* going low) but provides no vector information for the interrupt. This is the same as Type C interrupts except that no vector is supplied and DTACK\* is not asserted.

**Type C Interrupts** The interrupting M-Module removes the interrupt request via a hardware method and provides an interrupt vector on the data bus and DTACK\* is asserted during the interrupt acknowledge cycle. The M-Module removes the interrupt request by IACK\* going low.

In VXI specifications however, only two types of interrupts are defined; RORA (Release on Register Access) and ROAK (Release on Acknowledge). The Agilent E2251A Carrier converts M-Module Type A interrupts to RORA and Types B and C interrupts to ROAK (default).

**RORA Interrupts** The interrupting device provides its logical address on the data bus (MD0 - MD7) during the interrupt acknowledge cycle that was initiated in response to its interrupt request. It does not remove the interrupt request until its Status/Control register is accessed.

**ROAK Interrupts** The interrupting device removes the interrupt request upon the presence of a properly addressed interrupt acknowledge cycle and provides its logical address on the data bus (MD0 - MD7). A cause/status byte is also placed on the data bus (MD15 - MD8)

## Registers in A24 Address Space

There are several registers including a Status Register, Control Register, Interrupt Register, Delay Register, the Input/Output Register, and the Read/Write Decoder registers plus an EEPROM in A24 address space of the Breadboard Module. The Module also provides a set of decoder lines located from 20<sub>h</sub> through 2E<sub>h</sub>. Table 3-2 lists the address mapping

**Table 3-2. Agilent E2259A Registers in A24 Memory**

Address	Registers
FE <sub>h</sub>	EEPROM
30 <sub>h</sub> - FC <sub>h</sub>	Reserved
20 <sub>h</sub> - 2E <sub>h</sub>	Read/Write Decoder Registers
16 <sub>h</sub> - 1E <sub>h</sub>	Reserved
14 <sub>h</sub>	I/O Register
12 <sub>h</sub>	Delay Register
10 <sub>h</sub>	Reserved
(06 <sub>h</sub> - 0F <sub>h</sub> )	Reserved
04 <sub>h</sub>	Interrupt Register
02 <sub>h</sub>	Control Register
00 <sub>h</sub>	Status Register

**A24 Status Register** The offset of Status Register is 00<sub>h</sub>. It is a Read only register

b+00 <sub>h</sub>	15	14	13	12	11	10	9	8	7	6	5	4	3	2	1	0
Write	Reserved															
Read	Reserved								Busy*	Reserved				EIRQX	RIRQX	

- BUSY\*: 0-Circuit is busy (not stable yet).
- EIRQX: 1-External interrupt
- RIRQX:1-Circuit interrupt.

**Control Register** The offset of Control Register is 02<sub>h</sub>. It is a Read/Write register

b+02 <sub>h</sub>	15	14	13	12	11	10	9	8	7	6	5	4	3	2	1	0
Write	Reserved											EENABLE	RENABLE	Soft Reset		
Read	Reserved											EENABLE	RENABLE	Soft Reset		

- EENABLE: 1 - Enable External interrupt;
- RENABLE: 1 - Enable circuit interrupt (After BUSY timer);
- Soft Reset: 1 - Soft Reset Agilent E2259A.

When power-on or reset, all bits of Control Register are set to zero.

**Interrupt Register** The offset of Interrupt Register is 04<sub>h</sub>. It is a Read only register.

b+04 <sub>h</sub>	15	14	13	12	11	10	9	8	7	6	5	4	3	2	1	0
Write	Reserved															
Read	Reserved															RIRQX

- RIRQX: 1 - Circuit interrupt

**BUSY Delay Timer Register** The offset of BUSY Delay Timer Register is 12<sub>h</sub>. It is a write only register. The value of this register determines the delay time between command execution and asserting interrupt. The delay time is determined by the formula:

$$\text{Delay Time} = (\text{Register value} + 1) * 0.031875 \text{ ms}$$

where: **Register value** can be from 0000<sub>h</sub> through FFFF<sub>h</sub>

- The default value of **Delay Time** is 13 ms (register value = 407<sub>10</sub> or 197<sub>h</sub>).

**I/O Register** The offset of the Input/Output Register is 14<sub>h</sub>. Reading this Register will get the status of TR0 - TR15 lines. Writing to this Register will latch MD15-MD0 into two 74ACTQ273 latches (BC0 - BC15).

b+14 <sub>h</sub>	15	14	13	12	11	10	9	8	7	6	5	4	3	2	1	0
Write	Output Bits (BC15 - BC0)															
Read	Input Bits (TR15 - TR0)															

- Writing a 1 sets bit high; writing a 0 sets bit low.

## Read/Write Decoder Lines Registers

Writing a value to one of these registers asserts the corresponding WP line. Reading from one of these registers asserts the corresponding RP line. These decoder lines can be used to expand the I/O registers. Refer to Chapter 2 for timing information and using these registers.

$b+20_h$ - $b+2E_h$	15	14	13	12	11	10	9	8	7	6	5	4	3	2	1	0
Write	Output Bits (BC15 - BC0)															
Read	Input Bits (TR15 - TR0)															

Table 3-3 lists the Read/Write Decoder Register Addresses and the corresponding WP and RP lines.

**Table 3-3. Read/Write Decoder Lines and Register Addresses**

WP / RP Line	Register Address		WP / RP Line	Register Address
<b>WP0 / RP0</b>	20 <sub>h</sub> in A24 Memory		<b>WP4 / RP4</b>	28 <sub>h</sub> in A24 Memory
<b>WP1 / RP1</b>	22 <sub>h</sub> in A24 Memory		<b>WP5 / RP5</b>	2A <sub>h</sub> in A24 Memory
<b>WP2 / RP2</b>	24 <sub>h</sub> in A24 Memory		<b>WP6 / RP6</b>	2C <sub>h</sub> in A24 Memory
<b>WP3 / RP3</b>	26 <sub>h</sub> in A24 Memory		<b>WP7 / RP7</b>	2E <sub>h</sub> in A24 Memory

**EEPROM** There is an EEPROM on the Breadboard for identification. The offset of it is  $FE_h$  in A24 address space. The size of the EEPROM is 64 words (128 byte) and all the characteristics of M-Module are stored in it. The first 16 words (0 through 15) are defined in the M-Module Specifications; words 16 - 63 are described in Table 3-4.

**Table 3-4. EEPROM Contents**

Word #	Description	Value
0	Sync code	5346 <sub>h</sub>
1	module number (binary code)	1659 <sub>h</sub>
2	revision number (binary code)	0001
3	module characteristics	1868 <sub>h</sub>
4 - 7	reserved	
8 - 15	User-defined	
16	VXI Sync code	ACBA <sub>h</sub> (2's complement of 0x5346)
17	VXI-ID	CFFF <sub>h</sub>
18	VXI-Device Type	F258 <sub>h</sub>
19 - 31	Reserved	
32 - 47	User-defined	
48 - 63	Reserved	

# Appendix A

## Agilent E2259A Specifications

---

The Agilent E2259A Double-Wide Breadboard Module complies with the Mezzanine Concept M-Module Specification.

The specifications of Agilent E2259A are listed in the following table:

ITEM	SPECIFICATIONS
User Component Area	70 cm <sup>2</sup> (10.86 in <sup>2</sup> ) occupying two slots.
Grid Hole Spacing	2.54 mm (0.1 in.)
Grid Hole Inside Diameter	1.17 mm (0.046 in.)
Maximum Component Height	5.3 mm (0.21 in.) above board in Region A, 10.5 mm (0.42 in.) above board in Region B. Refer to "Agilent E2259A Connectors Layout" on page 13.
Maximum Lead Length	1.2 mm (0.078 in.) below board. Refer to "Agilent E2259A Connectors Layout" on page 13.
Maximum Power Dissipation (per module)	Determined by mainframe cooling and/or Agilent E2251A Cooling Capacity. Do not exceed 40 Watts.
Power Supplies	+5 VDC ±5% @ 100mA maximum +12 VDC ±5% @ 200mA maximum -12VDC ±5% @ 200mA maximum
Connectors	Two 44-pin connectors (user interface), Two 40-pin connectors to the carrier





## A

A01 to A07, [16](#)  
A16 Base Address, [32](#)  
A16/A24 Memory Mapping, [31](#)  
A24 Control Register, [42](#)  
A24 I/O Register, [42](#)  
A24 Interrupt Register, [42](#)  
A24 Status Register, [41](#)  
A24-Offset Register, [38](#)  
Access Pads, [13](#)  
Addressing A16 Registers  
    A16 Registers, Addressing, [33](#)  
Addressing A24 Registers  
    A24 Registers, Addressing, [33](#)  
Application Example, [29](#)

## B

Base Address, [32](#)  
Block Diagram, [10](#)  
Breadboard Description, [9](#)  
BUSY Delay Timer Register, [42](#)

## C

Component Height Restrictions, [13](#)  
Configuring the Module, [12](#)  
Connectors, [13](#)  
Control Register, [38](#)  
Control Register, A24, [42](#)  
CS\*, [16](#)

## D

D00 to D15, [16](#)  
DACK\*, [16](#)  
Decoder Lines, [21](#)  
Decoder Lines Register, [43](#)  
Delay Timer Register, [42](#)  
Description, Module, [9](#)  
Device Type Register, [37](#)  
DREQ\*, [17](#)  
DS0\* - DS1\*, [17](#)  
DTACK\*, [17](#)

## E

EEPROM, [10, 44](#)  
EEPROM Words, [44](#)

Example

    Application, [29](#)  
    Program, [25](#)

## F

Features, [9](#)

## G

General Features, [9](#)

## I

I/O Decoder Lines Register, [43](#)  
IACK\*, [17, 24](#)  
ID EEPROM, [10, 44](#)  
ID Register, [37](#)  
Input Circuit, [10](#)  
Input Registers, [22](#)  
Interrupt, [24](#)  
Interrupt Register, A24, [42](#)  
Interrupt Selection Register, [39](#)  
IRQ\*, [17](#)

## J

J100, [13, 14](#)  
J101, [13, 14](#)  
J102, [13, 15](#)  
J103, [13, 15](#)  
J104, [13, 14](#)  
J105, [13, 14](#)

## L

Logical Address, [31](#)

## M

Module Configuration, [12](#)  
Module Control, [10](#)  
Module Description, [9](#)  
Module Specifications, [45](#)

## O

Output Circuit, [10](#)

## **P**

P100, [13](#), [16](#)  
P101, [13](#), [16](#)  
P102, [16](#)  
Pin Assignments, [14](#), [15](#), [16](#)  
Power Supplies, [10](#), [28](#)  
Program Example, [25](#)

## **R**

Read Decoder Lines, [23](#)  
Reading Data From Input Registers, [22](#)  
Register  
    A24 Control, [42](#)  
    A24 I/O, [42](#)  
    A24 Interrupt, [42](#)  
    A24 Offset, [38](#)  
    A24 Status, [41](#)  
    BUSY Delay Timer, [42](#)  
    Device Type, [37](#)  
    I/O Decoder Lines, [43](#)  
    ID, [37](#)  
    Interrupt Selection, [39](#)  
    Status/Control, [38](#)  
Register Addressing, [31](#)  
Registers, [19](#)  
RESET\*, [17](#)  
Resetting the Module, [28](#)  
Restrictions, Component height, [13](#)

## **S**

Specifications, [45](#)  
Status Register, A24, [41](#)  
Status/Control Register, [38](#)  
SYSCLK, [17](#)

## **V**

VXI A24-Offset Register, [38](#)  
VXI Device Type Register, [37](#)  
VXI ID Register, [37](#)  
VXI Status/Control Register, [38](#)

## **W**

W14\*, [20](#)  
Write Decoder Lines, [21](#)  
WRITE\*, [17](#)